

Dual 1:2 Low Additive Jitter LVDS Buffer

Check for Samples: [CDCLVD2102](#)

FEATURES

- Dual 1:2 Differential Buffer
- Low Additive Jitter <300 fs RMS in 10-kHz to 20-MHz
- Low Within Bank Output Skew of 15 ps (Max)
- Universal Inputs Accept LVDS, LVPECL, LVCMOS
- One Input Dedicated for Two Outputs
- Total of 4 LVDS Outputs, ANSI EIA/TIA-644A Standard Compatible
- Clock Frequency up to 800 MHz
- 2.375–2.625V Device Power Supply
- LVDS Reference Voltage, V_{AC_REF} , Available for Capacitive Coupled Inputs
- Industrial Temperature Range –40°C to 85°C
- Packaged in 3mm × 3mm 16-Pin QFN (RGT)
- ESD Protection Exceeds 3 kV HBM, 1 kV CDM

APPLICATIONS

- Telecommunications/Networking
- Medical Imaging
- Test and Measurement Equipment
- Wireless Communications
- General Purpose Clocking

DESCRIPTION

The CDCLVD2102 clock buffer distributes two clock inputs (IN0, IN1) to a total of 4 pairs of differential LVDS clock outputs (OUT0, OUT3). Each buffer block consists of one input and 2 LVDS outputs. The inputs can either be LVDS, LVPECL, or LVCMOS.

The CDCLVD2102 is specifically designed for driving 50-Ω transmission lines. If driving the inputs in single ended mode, the appropriate bias voltage (V_{AC_REF}) should be applied to the unused negative input pin.

Using the control pin (EN), outputs can be either disabled or enabled. If the EN pin is left open two buffers with all outputs are enabled, if switched to a logical "0" both buffers with all outputs are disabled (static logical "0"), if switched to a logical "1", one buffer with two outputs is disabled and another buffer with two outputs is enabled. The part supports a fail safe function. It incorporates an input hysteresis, which prevents random oscillation of the outputs in absence of an input signal.

The device operates in 2.5V supply environment and is characterized from –40°C to 85°C (ambient temperature). The CDCLVD2102 is packaged in small 16-pin, 3-mm × 3-mm QFN package.

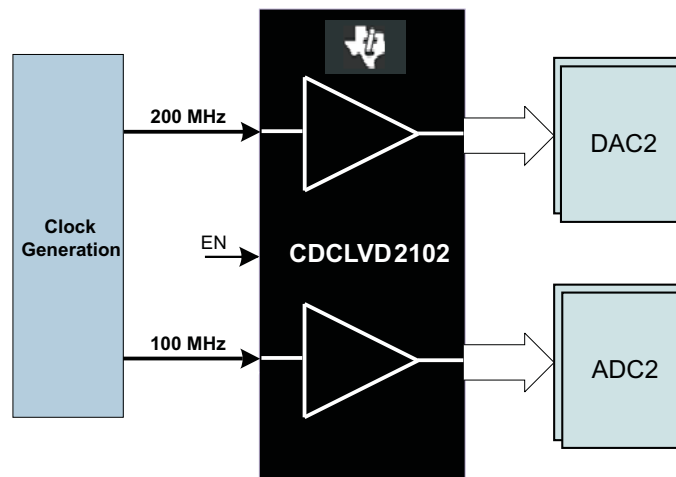

Figure 1. Application Example



Please be aware that an important notice concerning availability, standard warranty, and use in critical applications of Texas Instruments semiconductor products and disclaimers thereto appears at the end of this data sheet.



These devices have limited built-in ESD protection. The leads should be shorted together or the device placed in conductive foam during storage or handling to prevent electrostatic damage to the MOS gates.

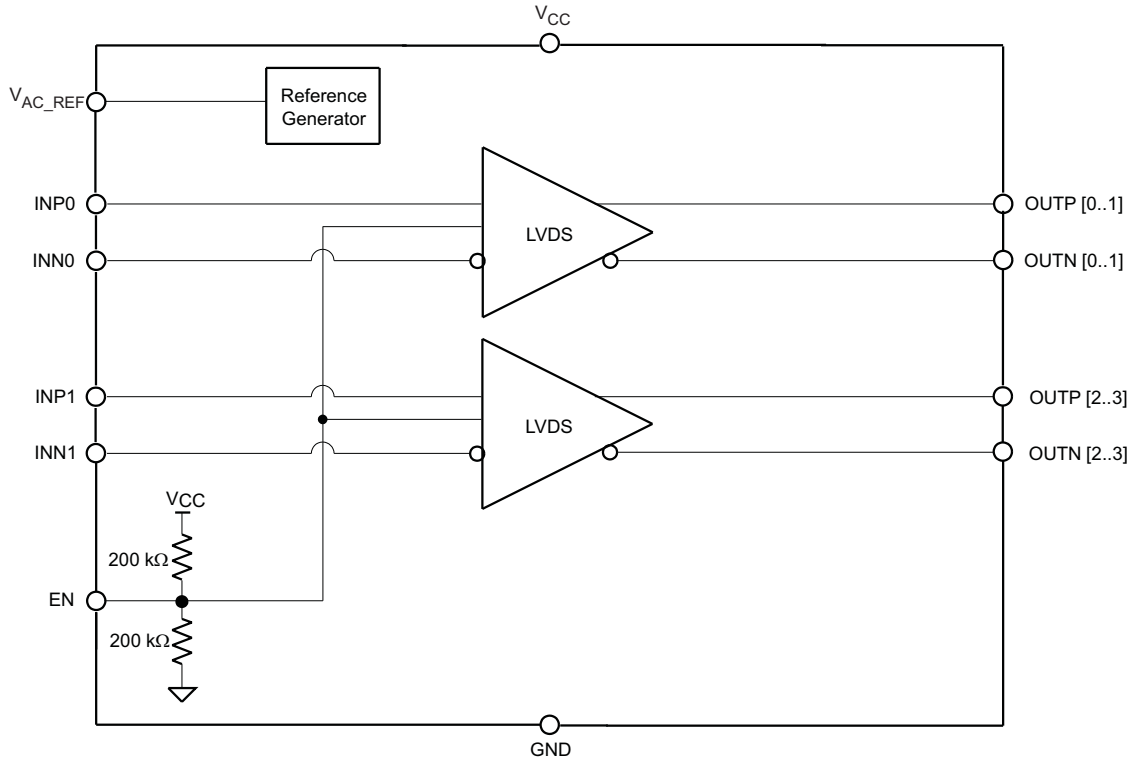
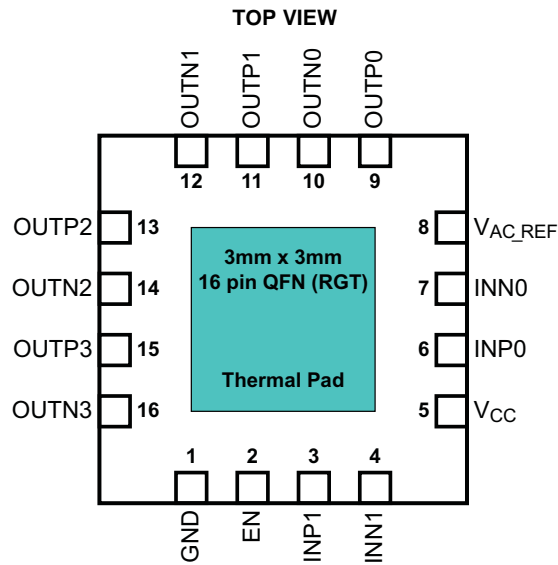

Figure 2. CDCLVD2102 Block Diagram



PIN FUNCTIONS

PIN		TYPE	DESCRIPTION	
NAME	NO.			
VCC	5	Power	2.5V supplies for the device	
GND	1	Ground	Device ground	
INP0, INN0	6, 7	Input	Differential input pair or single ended input	
INP1, INN1	3, 4	Input	Differential redundant input pair or single ended input	
V _{AC_REF}	8	Output	Bias voltage output for capacitive coupled inputs. If used, it is recommended to use a 0.1µF to GND on this pin	
OUTP0, OUTN0	9, 10	Output	Differential LVDS output pair no. 0	INP0/INN0 is the input
OUTP1, OUTN1	11, 12	Output	Differential LVDS output pair no. 1	
OUTP2, OUTN2	13, 14	Output	Differential LVDS output pair no. 2	INP1/INN1 is the input
OUTP3, OUTN3	15, 16	Output	Differential LVDS output pair no. 3	
EN	2	Input with internal 200kΩ pull-up and pull-down	Control pin – enables or disables the outputs, (See Table 1)	
Thermal Pad			See thermal management recommendations	

Table 1. Output Control Table

EN	CLOCK OUTPUTS
0	All outputs disabled (static "0")
OPEN	All outputs enabled
1	OUT0, OUT1 enabled and OUT2, OUT3 disabled (static "0")

ABSOLUTE MAXIMUM RATINGS

 over operating free-air temperature range (unless otherwise noted)⁽¹⁾

	VALUE / UNIT
Supply voltage range, V _{CC}	–0.3 to 2.8 V
Input voltage, V _I	–0.2 to (V _{CC} + 0.2) V
Output voltage range, V _O	–0.2 to (V _{CC} + 0.2) V
Driver short circuit current, I _{OSD}	See Note ⁽²⁾
Electrostatic discharge (HBM, 1.5 kΩ, 100 pF)	>3000 V

(1) Stresses beyond those listed under “absolute maximum ratings” may cause permanent damage to the device. These are stress ratings only and functional operation of the device at these or any other conditions beyond those indicated under recommended operating conditions” is not implied. Exposure to absolute–maximum–rated conditions for extended periods may affect device reliability.

(2) The outputs can handle permanent short.

RECOMMENDED OPERATING CONDITIONS

	MIN	TYP	MAX	UNITS
Device supply voltage, V _{CC}	2.375	2.5	2.625	V
Ambient temperature, T _A	–40		85	°C

THERMAL INFORMATION

THERMAL METRIC ⁽¹⁾		CDCLVD2102	UNITS
		RGT	
		16 PINS	
θ_{JA}	Junction-to-ambient thermal resistance	51.3	°C/W
$\theta_{JC(top)}$	Junction-to-case(top) thermal resistance	85.4	
θ_{JB}	Junction-to-board thermal resistance	20.1	
ψ_{JT}	Junction-to-top characterization parameter	1.3	
ψ_{JB}	Junction-to-board characterization parameter	19.4	
$\theta_{JC(bottom)}$	Junction-to-case(bottom) thermal resistance	6	

(1) For more information about traditional and new thermal metrics, see the *IC Package Thermal Metrics* application report, [SPRA953](#).

ELECTRICAL CHARACTERISTICS:

At $V_{CC} = 2.375\text{ V}$ to 2.625 V and $T_A = -40^\circ\text{C}$ to 85°C (unless otherwise noted).

PARAMETER	TEST CONDITIONS	MIN	TYP	MAX	UNIT
EN PIN INPUT CHARACTERISTICS					
V_{dI3}	3-State	Open	$0.5 \times V_{CC}$		V
V_{dIH}	Input high voltage		$0.7 \times V_{CC}$		V
V_{dIL}	Input low voltage			$0.2 \times V_{CC}$	V
I_{dIH}	Input high current	$V_{CC} = 2.625\text{ V}$, $V_{IH} = 2.625\text{ V}$		30	μA
I_{dIL}	Input low current	$V_{CC} = 2.625\text{ V}$, $V_{IL} = 0\text{ V}$		-30	μA
$R_{pull(EN)}$	Input pull-up/ pull-down resistor		200		k Ω
2.5V LVC MOS (see Figure 7) INPUT CHARACTERISTICS					
f_{IN}	Input frequency			200	MHz
V_{th}	Input threshold voltage	External threshold voltage applied to complementary input	1.1	1.5	V
V_{IH}	Input high voltage		$V_{th} + 0.1$	V_{CC}	V
V_{IL}	Input low voltage		0	$V_{th} - 0.1$	V
I_{IH}	Input high current	$V_{CC} = 2.625\text{ V}$, $V_{IH} = 2.625\text{ V}$		10	μA
I_{IL}	Input low current	$V_{CC} = 2.625\text{ V}$, $V_{IL} = 0\text{ V}$		-10	μA
$\Delta V/\Delta T$	Input edge rate	20% – 80%	1.5		V/ns
C_{IN}	Input capacitance		2.5		pF
DIFFERENTIAL INPUT CHARACTERISTICS					
f_{IN}	Input frequency	Clock input		800	MHz
$V_{IN, DIFF}$	Differential input voltage peak-to-peak	$V_{ICM} = 1.25\text{ V}$	0.3	1.6	V_{P-P}
V_{ICM}	Input common-mode voltage range	$V_{IN, DIFF, PP} > 0.4\text{ V}$	1	$V_{CC} - 0.3$	V
I_{IH}	Input high current	$V_{CC} = 2.625\text{ V}$, $V_{IH} = 2.625\text{ V}$		10	μA
I_{IL}	Input low current	$V_{CC} = 2.625\text{ V}$, $V_{IL} = 0\text{ V}$		-10	μA
$\Delta V/\Delta T$	Input edge rate	20% to 80%	0.75		V/ns
C_{IN}	Input capacitance		2.5		pF

ELECTRICAL CHARACTERISTICS: (continued)

 At $V_{CC} = 2.375\text{ V}$ to 2.625 V and $T_A = -40^\circ\text{C}$ to 85°C (unless otherwise noted).

PARAMETER		TEST CONDITIONS	MIN	TYP	MAX	UNIT
LVDS OUTPUT CHARACTERISTICS						
$ V_{OD} $	Differential output voltage magnitude	$V_{IN, DIFF, PP} = 0.3\text{ V}, R_L = 100\ \Omega$	250		450	mV
ΔV_{OD}	Change in differential output voltage magnitude		-15		15	mV
$V_{OC(SS)}$	Steady-state common mode output voltage		1.1		1.375	V
$\Delta V_{OC(SS)}$	Steady-state common mode output voltage	$V_{IN, DIFF, PP} = 0.6\text{ V}, R_L = 100\ \Omega$	-15		15	mV
V_{ring}	Output overshoot and undershoot	Percentage of output amplitude V_{OD}			10%	
V_{OS}	Output ac common mode	$V_{IN, DIFF, PP} = 0.6\text{ V}, R_L = 100\ \Omega$		25	70	mV _{PP}
I_{OS}	Short-circuit output current	$V_{OD} = 0\text{ V}$			± 24	mA
t_{PD}	Propagation delay	$V_{IN, DIFF, PP} = 0.3\text{ V}$		1.5	2.5	ns
$t_{SK, PP}$	Part-to-part skew				600	ps
t_{SK, O_WB}	Within bank output skew				15	ps
t_{SK, O_BB}	Bank-to-bank output skew	Both inputs are phase aligned			100	ps
$t_{SK, P}$	Pulse skew(with 50% duty cycle input)	Crossing-point-to-crossing-point distortion	-50		50	ps
t_{RJIT}	Random additive jitter (with 50% duty cycle input)	Edge speed = 0.75 V/ns , 10 kHz – 20 MHz			0.3	ps, RMS
t_R/t_F	Output rise/fall time	20% to 80%, $100\ \Omega$, 5 pF	50		300	ps
I_{CCSTAT}	Static supply current	Outputs unterminated, $f = 0\text{ Hz}$		27	45	mA
I_{CC100}	Supply current	All outputs enabled, $R_L = 100\ \Omega$, $f = 100\text{ MHz}$		49	77	mA
I_{CC800}	Supply current	All outputs enabled, $R_L = 100\ \Omega$, $f = 800\text{ MHz}$		76	106	mA
V_{AC_REF} CHARACTERISTICS						
V_{AC_REF}	Reference output voltage	$V_{CC} = 2.5\text{ V}, I_{load} = 100\ \mu\text{A}$	1.1	1.25	1.35	V

Typical Additive Phase Noise Characteristics for 100 MHz Clock

PARAMETER		MIN	TYP	MAX	UNIT
phn ₁₀₀	Phase noise at 100 Hz offset		-132.9		dBc/Hz
phn _{1k}	Phase noise at 1 kHz offset		-138.8		dBc/Hz
phn _{10k}	Phase noise at 10 kHz offset		-147.4		dBc/Hz
phn _{100k}	Phase noise at 100 kHz offset		-153.6		dBc/Hz
phn _{1M}	Phase noise at 1 MHz offset		-155.2		dBc/Hz
phn _{10M}	Phase noise at 10 MHz offset		-156.2		dBc/Hz
phn _{20M}	Phase noise at 20 MHz offset		-156.6		dBc/Hz
t _{RJIT}	Random additive jitter from 10 kHz to 20 MHz		171		fs, RMS

Typical Additive Phase Noise Characteristics for 737.27 MHz Clock

PARAMETER		MIN	TYP	MAX	UNIT
phn ₁₀₀	Phase noise at 100 Hz offset		-80.2		dBc/Hz
phn _{1k}	Phase noise at 1 kHz offset		-114.3		dBc/Hz
phn _{10k}	Phase noise at 10 kHz offset		-138		dBc/Hz
phn _{100k}	Phase noise at 100 kHz offset		-143.9		dBc/Hz
phn _{1M}	Phase noise at 1 MHz offset		-145.2		dBc/Hz
phn _{10M}	Phase noise at 10 MHz offset		-146.5		dBc/Hz
phn _{20M}	Phase noise at 20 MHz offset		-146.6		dBc/Hz
t _{RJIT}	Random additive jitter from 10 kHz to 20 MHz		65		fs, RMS

TYPICAL CHARACTERISTICS
INPUT CLOCK AND OUTPUT CLOCK PHASE NOISES
 vs
FREQUENCY FROM THE CARRIER ($T_A = 25^\circ\text{C}$ and $V_{CC} = 2.5\text{V}$)

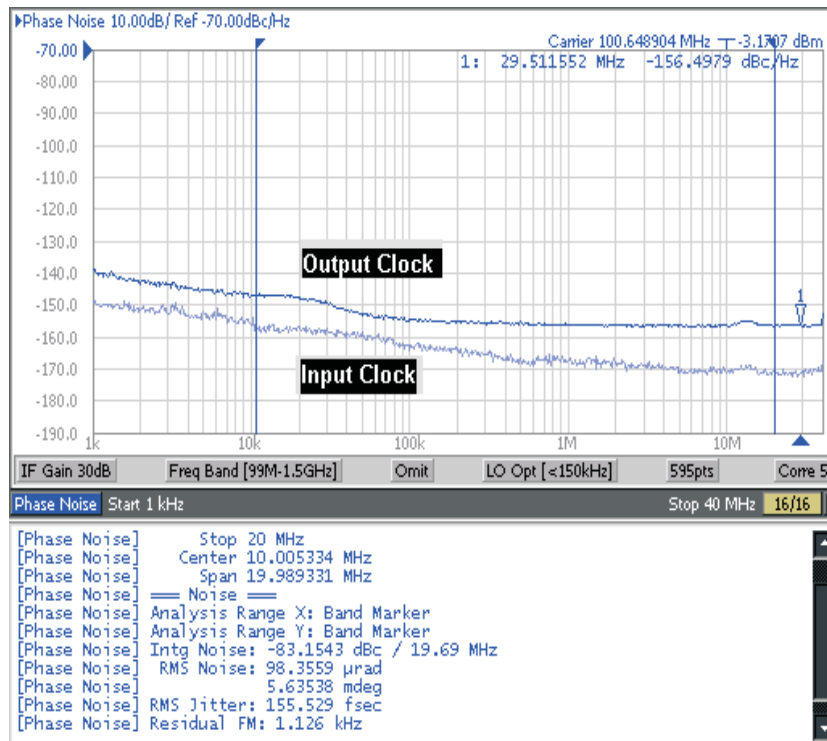

Input clock jitter is 32 fs from 10 kHz to 20 MHz and additive RMS jitter is 152 fs

Figure 3. 100 MHz Input and Output Phase Noise Plot

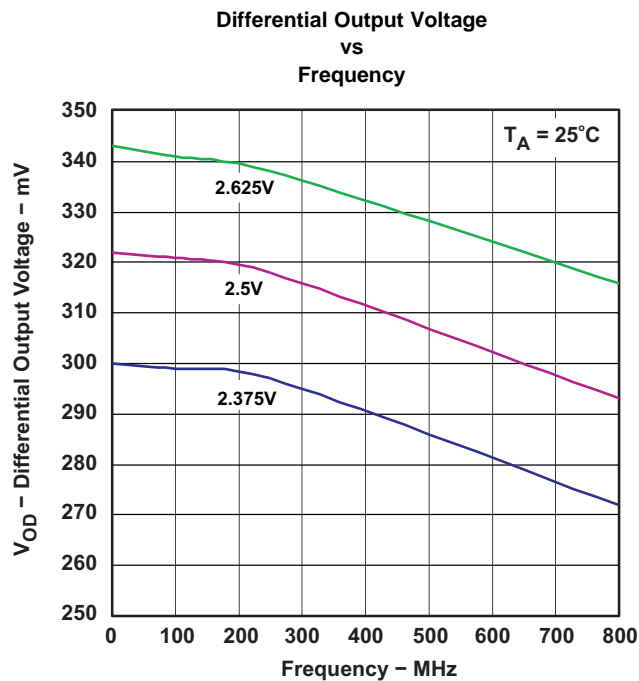

Figure 4.

TEST CONFIGURATIONS

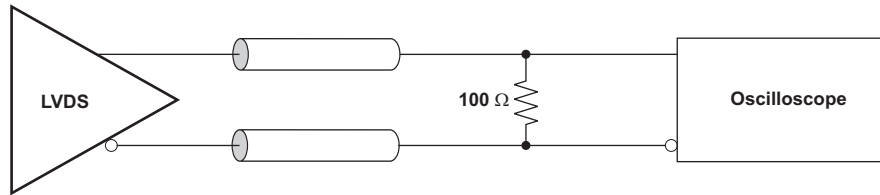

Figure 5. LVDS Output DC Configuration During Device Test

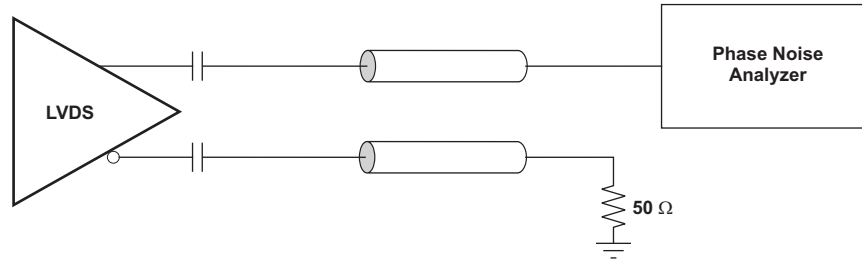

Figure 6. LVDS Output AC Configuration During Device Test

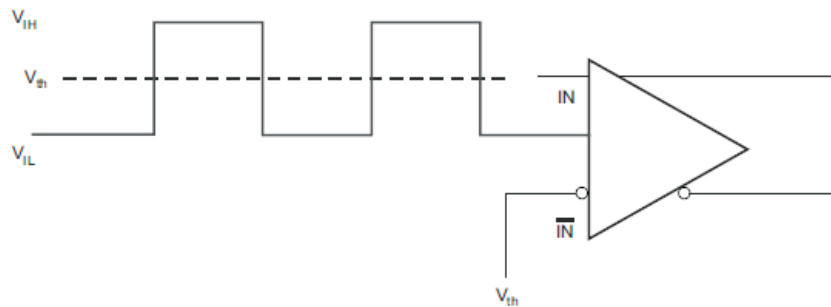

Figure 7. DC Coupled LVCMOS Input During Device Test

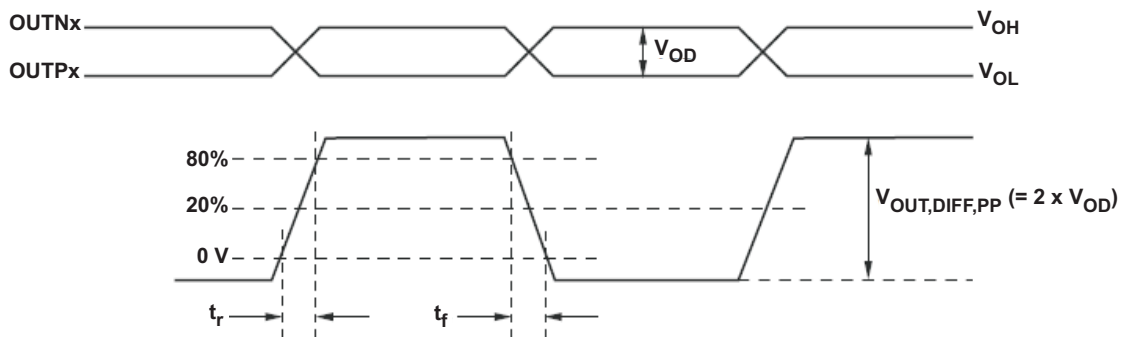
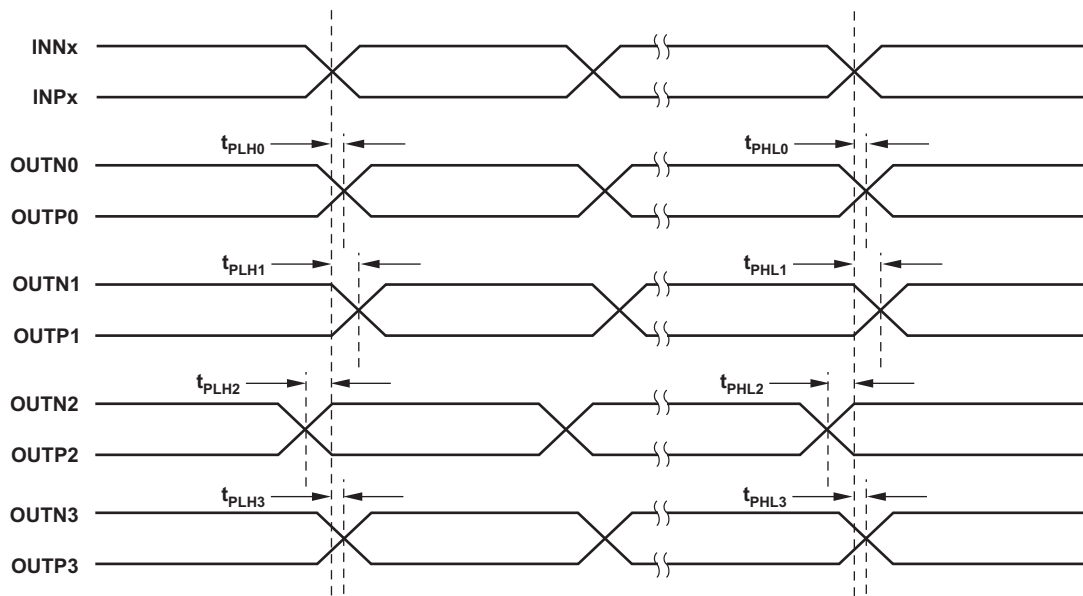

Figure 8. Output Voltage and Rise/Fall Time



- Output skew is calculated as the greater of the following: As the difference between the fastest and the slowest t_{PLH_n} or the difference between the fastest and the slowest t_{PHL_n} ($n = 0, 1, 2, 3$).
- Part-to-part skew is calculated as the greater of the following: As the difference between the fastest and the slowest t_{PLH_n} or the difference between the fastest and the slowest t_{PHL_n} across multiple devices ($n = 0, 1, 2, 3$).
- Both inputs (IN_0 and IN_1) are phase aligned.

Figure 9. Output Skew and Part-to-Part Skew

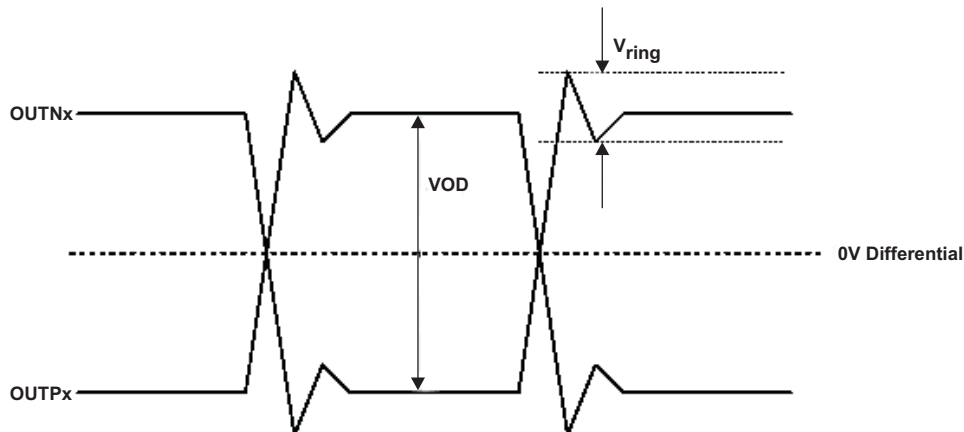

Figure 10. Output Overshoot and Undershoot

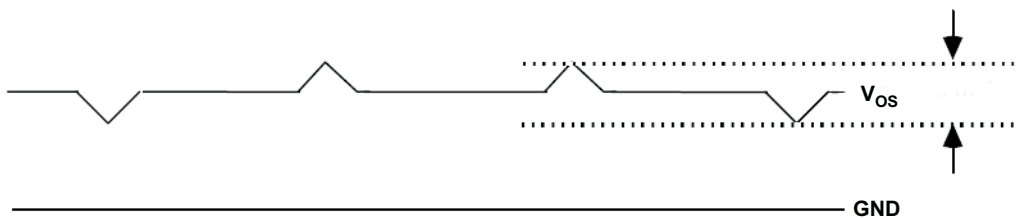

Figure 11. Output AC Common Mode

APPLICATION INFORMATION

THERMAL MANAGEMENT

For reliability and performance reasons, the die temperature should be limited to a maximum of 125°C.

The device package has an exposed pad that provides the primary heat removal path to the printed circuit board (PCB). To maximize the heat dissipation from the package, a thermal landing pattern including multiple vias to a ground plane must be incorporated into the PCB within the footprint of the package. The Thermal Pad must be soldered down to ensure adequate heat conduction to of the package. Figure 12 shows a recommended land and via pattern.

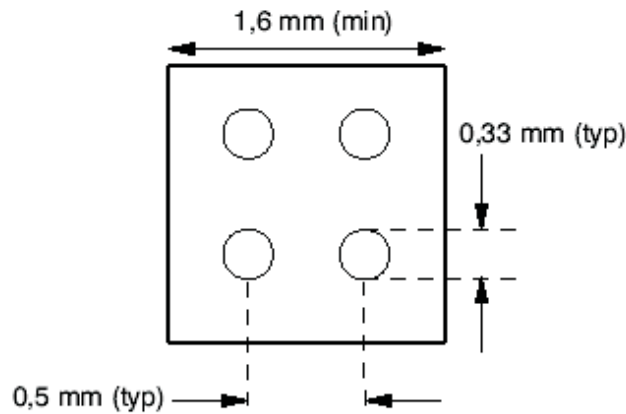

Figure 12. Recommended PCB Layout

POWER-SUPPLY FILTERING

High-performance clock buffers are sensitive to noise on the power supply, which can dramatically increase the additive jitter of the buffer. Thus, it is essential to reduce noise from the system power supply, especially when jitter/phase noise is critical to applications.

Filter capacitors are used to eliminate the low-frequency noise from the power supply, where the bypass capacitors provide the very low impedance path for high-frequency noise and guard the power-supply system against the induced fluctuations. These bypass capacitors also provide instantaneous current surges as required by the device and should have low equivalent series resistance (ESR). To properly use the bypass capacitors, they must be placed very close to the power-supply pins and laid out with short loops to minimize inductance. It is recommended to add as many high-frequency (for example, 0.1 μF) bypass capacitors as there are supply pins in the package. It is recommended, but not required, to insert a ferrite bead between the board power supply and the chip power supply that isolates the high-frequency switching noises generated by the clock driver; these beads prevent the switching noise from leaking into the board supply. Choose an appropriate ferrite bead with very low dc resistance because it is imperative to provide adequate isolation between the board supply and the chip supply, as well as to maintain a voltage at the supply pins that is greater than the minimum voltage required for proper operation.

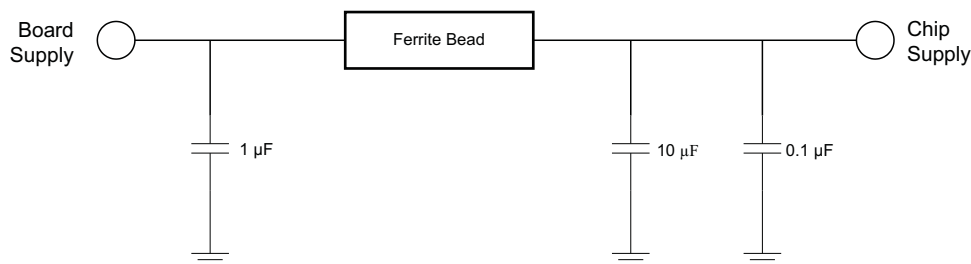

Figure 13. Power-Supply Decoupling

LVDS OUTPUT TERMINATION

The proper LVDS termination for signal integrity over two 50 Ω lines is 100 Ω between the outputs on the receiver end. Either dc-coupled termination or ac-coupled termination can be used for LVDS outputs. It is recommended to place termination resistor close to the receiver. If the receiver is internally biased to a voltage different than the output common mode voltage of the CDCLVD2102, ac-coupling should be used. If the LVDS receiver has internal 100 ohm termination, external termination must be omitted.

Unused outputs can be left open without connecting any trace to the output pins.

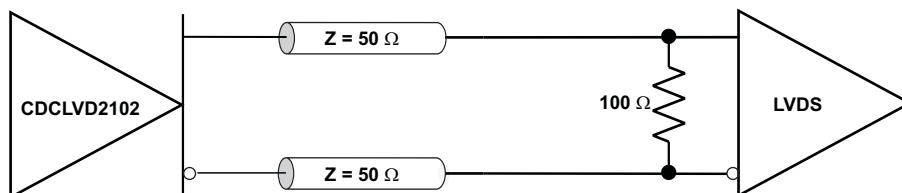

Figure 14. Output DC Termination

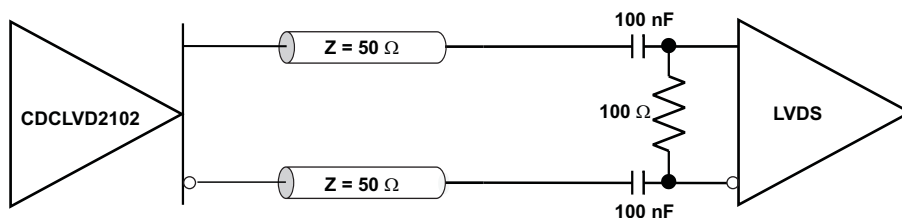

Figure 15. Output AC Termination With Receiver Internally Biased

INPUT TERMINATION

The CDCLVD2102 inputs can be interfaced with LVDS, LVPECL, or LVCMOS drivers.

LVDS Driver can be connected to CDCLVD2102 inputs with dc or ac coupling as shown [Figure 16](#) and [Figure 17](#), respectively.

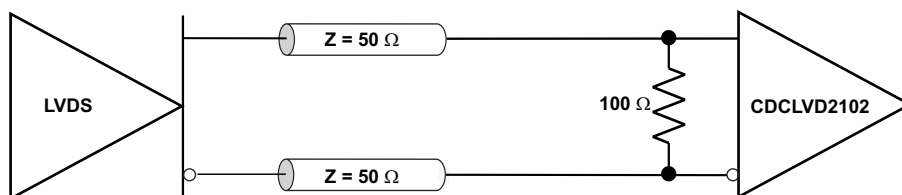

Figure 16. LVDS Clock Driver Connected to CDCLVD2102 Input (DC Coupled)

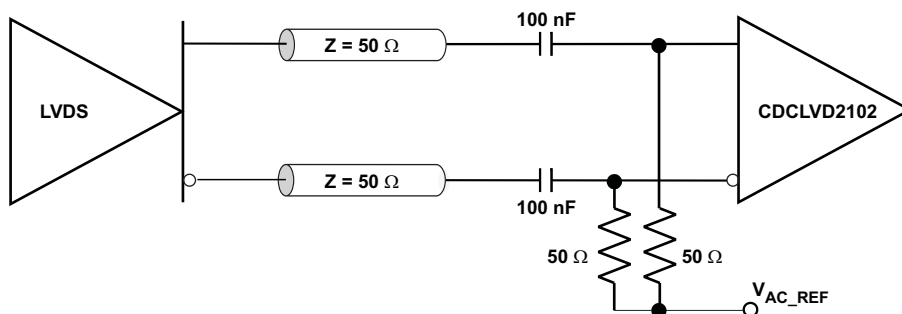

Figure 17. LVDS Clock Driver Connected to CDCLVD2102 Input (AC Coupled)

Figure 18 shows how to connect LVPECL inputs to the CDCLVD2102. The series resistors are required to reduce the LVPECL signal swing if the signal swing is $>1.6 V_{PP}$.

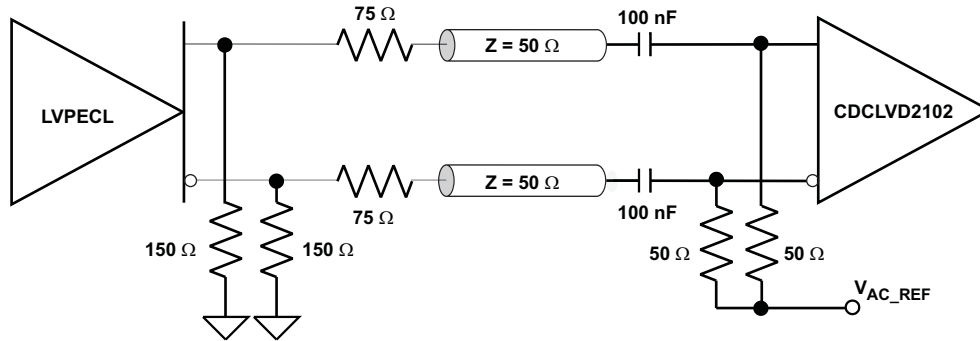

Figure 18. LVPECL Clock Driver Connected to CDCLVD2102 Input

Figure 19 illustrates how to couple a 2.5 V LVCMOS clock input to the CDCLVD2102 directly. The series resistance (R_S) should be placed close to the LVCMOS driver if needed. 3.3 V LVCMOS clock input swing needs to be limited to $V_{IH} \leq V_{CC}$.

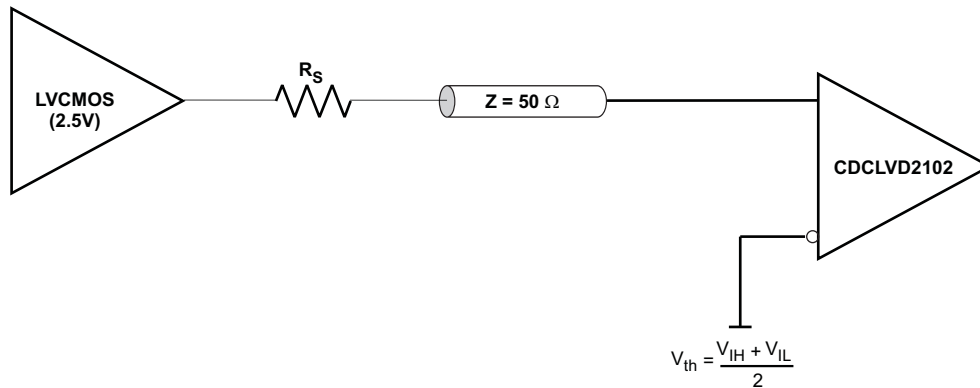

Figure 19. 2.5V LVCMOS Clock Driver Connected to CDCLVD2102 Input

If one of the buffers is used, then the other unused buffer should be disabled through the EN pin, and the unused input pins should be grounded by 1kΩ resistors.

REVISION HISTORY

Changes from Original (May 2010) to Revision A	Page
• Changed Features bullet From: ESD Protection Exceeds 2kV HBM, 500V CDM To: ESD Protection Exceeds 3 kV HBM, 1 kV CDM	1
• Electrostatic discharge was <2000	3
• ΔV_{OD} values, MIN was -50, MAX was 50	5
• $V_{OC(SS)}$ MIN value was 1.125	5
• $\Delta V_{OC(SS)}$ values, MIN was -50, MAX was 50	5
• V_{ring} MAX value was 20%	5
• V_{OS} values, TYP was 30, MAX was 100	5
• t_{PD} MAX value was 2	5
• $t_{SK, PP}$ - deleted the TYP value of 300	5
• t_R/t_F MIN value was 200	5
• I_{CCSTAT} MAX value was 42	5
• Added new paragraph following Figure 19	12

PACKAGING INFORMATION

Orderable Device	Status (1)	Package Type	Package Drawing	Pins	Package Qty	Eco Plan (2)	Lead/Ball Finish	MSL Peak Temp (3)	Op Temp (°C)	Top-Side Markings (4)	Samples
CDCLVD2102RGTR	ACTIVE	QFN	RGT	16	3000	Green (RoHS & no Sb/Br)	CU NIPDAU	Level-2-260C-1 YEAR	-40 to 85	D2102	Samples
CDCLVD2102RGTT	ACTIVE	QFN	RGT	16	250	Green (RoHS & no Sb/Br)	CU NIPDAU	Level-2-260C-1 YEAR	-40 to 85	D2102	Samples

(1) The marketing status values are defined as follows:

ACTIVE: Product device recommended for new designs.

LIFEBUY: TI has announced that the device will be discontinued, and a lifetime-buy period is in effect.

NRND: Not recommended for new designs. Device is in production to support existing customers, but TI does not recommend using this part in a new design.

PREVIEW: Device has been announced but is not in production. Samples may or may not be available.

OBSOLETE: TI has discontinued the production of the device.

(2) Eco Plan - The planned eco-friendly classification: Pb-Free (RoHS), Pb-Free (RoHS Exempt), or Green (RoHS & no Sb/Br) - please check <http://www.ti.com/productcontent> for the latest availability information and additional product content details.

TBD: The Pb-Free/Green conversion plan has not been defined.

Pb-Free (RoHS): TI's terms "Lead-Free" or "Pb-Free" mean semiconductor products that are compatible with the current RoHS requirements for all 6 substances, including the requirement that lead not exceed 0.1% by weight in homogeneous materials. Where designed to be soldered at high temperatures, TI Pb-Free products are suitable for use in specified lead-free processes.

Pb-Free (RoHS Exempt): This component has a RoHS exemption for either 1) lead-based flip-chip solder bumps used between the die and package, or 2) lead-based die adhesive used between the die and leadframe. The component is otherwise considered Pb-Free (RoHS compatible) as defined above.

Green (RoHS & no Sb/Br): TI defines "Green" to mean Pb-Free (RoHS compatible), and free of Bromine (Br) and Antimony (Sb) based flame retardants (Br or Sb do not exceed 0.1% by weight in homogeneous material)

(3) MSL, Peak Temp. -- The Moisture Sensitivity Level rating according to the JEDEC industry standard classifications, and peak solder temperature.

(4) Multiple Top-Side Markings will be inside parentheses. Only one Top-Side Marking contained in parentheses and separated by a "~" will appear on a device. If a line is indented then it is a continuation of the previous line and the two combined represent the entire Top-Side Marking for that device.

Important Information and Disclaimer: The information provided on this page represents TI's knowledge and belief as of the date that it is provided. TI bases its knowledge and belief on information provided by third parties, and makes no representation or warranty as to the accuracy of such information. Efforts are underway to better integrate information from third parties. TI has taken and continues to take reasonable steps to provide representative and accurate information but may not have conducted destructive testing or chemical analysis on incoming materials and chemicals. TI and TI suppliers consider certain information to be proprietary, and thus CAS numbers and other limited information may not be available for release.

In no event shall TI's liability arising out of such information exceed the total purchase price of the TI part(s) at issue in this document sold by TI to Customer on an annual basis.

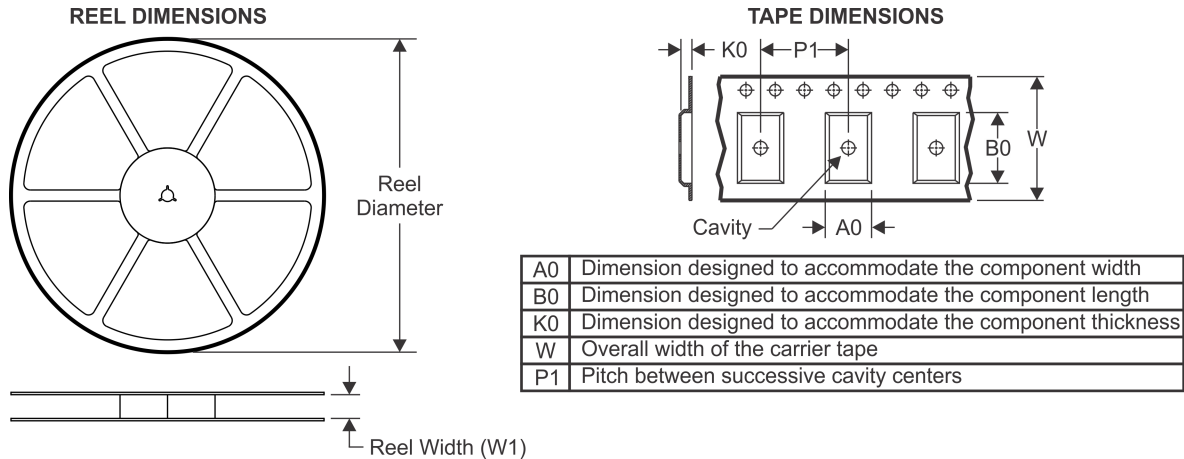
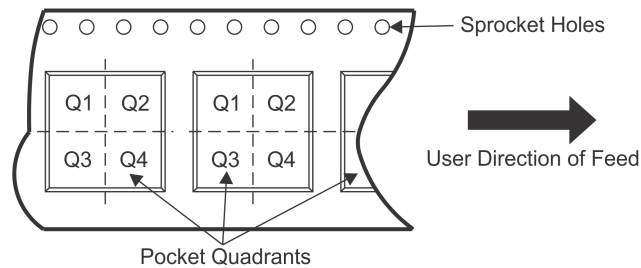
TAPE AND REEL INFORMATION

QUADRANT ASSIGNMENTS FOR PIN 1 ORIENTATION IN TAPE

*All dimensions are nominal

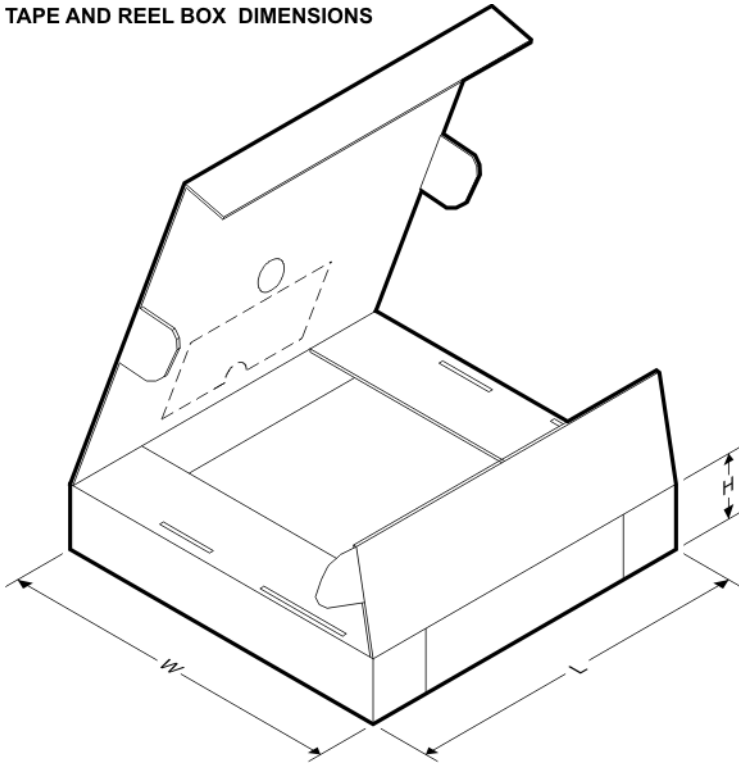
Device	Package Type	Package Drawing	Pins	SPQ	Reel Diameter (mm)	Reel Width W1 (mm)	A0 (mm)	B0 (mm)	K0 (mm)	P1 (mm)	W (mm)	Pin1 Quadrant
CDCLVD2102RGTR	QFN	RGT	16	3000	330.0	12.4	3.3	3.3	1.1	8.0	12.0	Q2
CDCLVD2102RGTT	QFN	RGT	16	250	180.0	12.4	3.3	3.3	1.1	8.0	12.0	Q2

TAPE AND REEL BOX DIMENSIONS

*All dimensions are nominal

Device	Package Type	Package Drawing	Pins	SPQ	Length (mm)	Width (mm)	Height (mm)
CDCLVD2102RGTR	QFN	RGT	16	3000	336.6	336.6	28.6
CDCLVD2102RGTT	QFN	RGT	16	250	210.0	185.0	35.0

RGT 16

GENERIC PACKAGE VIEW

VQFN - 1 mm max height

PLASTIC QUAD FLATPACK - NO LEAD

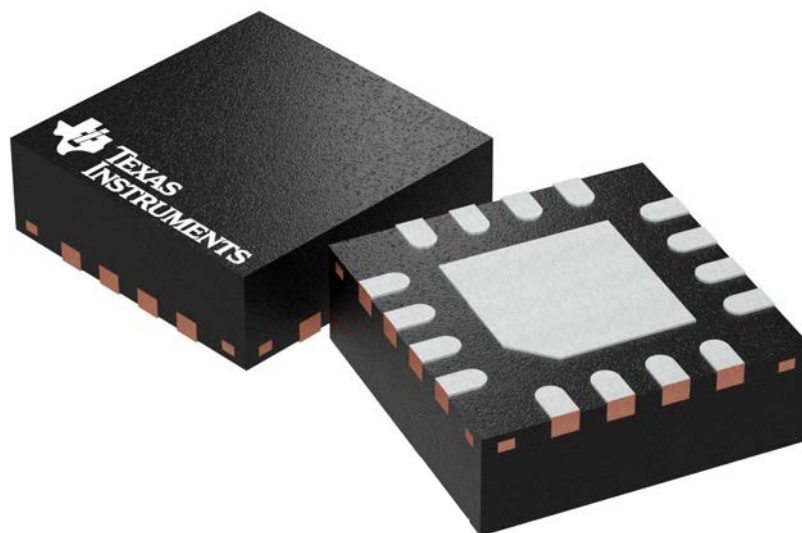

Images above are just a representation of the package family, actual package may vary.
Refer to the product data sheet for package details.

4203495/1

EXAMPLE STENCIL DESIGN

RGT0016C

VQFN - 1 mm max height

PLASTIC QUAD FLATPACK - NO LEAD

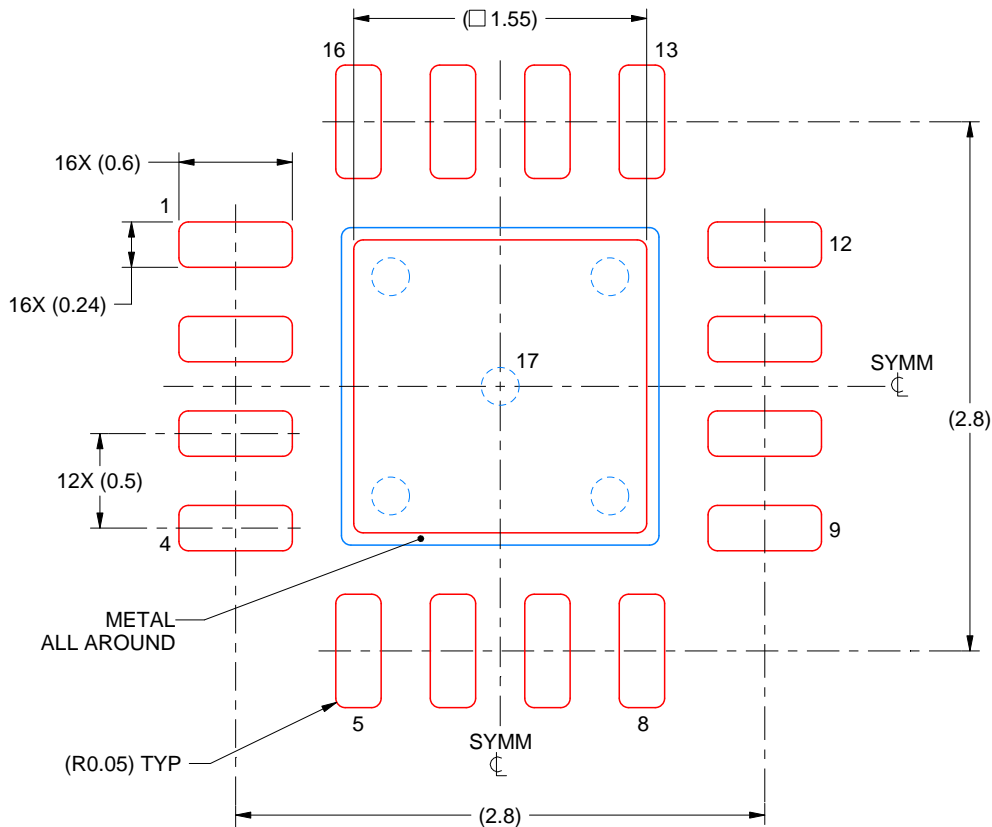

SOLDER PASTE EXAMPLE
BASED ON 0.125 mm THICK STENCIL

EXPOSED PAD 17:
85% PRINTED SOLDER COVERAGE BY AREA UNDER PACKAGE
SCALE:25X

4222419/B 11/2016

NOTES: (continued)

6. Laser cutting apertures with trapezoidal walls and rounded corners may offer better paste release. IPC-7525 may have alternate design recommendations.

IMPORTANT NOTICE FOR TI DESIGN INFORMATION AND RESOURCES

Texas Instruments Incorporated ("TI") technical, application or other design advice, services or information, including, but not limited to, reference designs and materials relating to evaluation modules, (collectively, "TI Resources") are intended to assist designers who are developing applications that incorporate TI products; by downloading, accessing or using any particular TI Resource in any way, you (individually or, if you are acting on behalf of a company, your company) agree to use it solely for this purpose and subject to the terms of this Notice.

TI's provision of TI Resources does not expand or otherwise alter TI's applicable published warranties or warranty disclaimers for TI products, and no additional obligations or liabilities arise from TI providing such TI Resources. TI reserves the right to make corrections, enhancements, improvements and other changes to its TI Resources.

You understand and agree that you remain responsible for using your independent analysis, evaluation and judgment in designing your applications and that you have full and exclusive responsibility to assure the safety of your applications and compliance of your applications (and of all TI products used in or for your applications) with all applicable regulations, laws and other applicable requirements. You represent that, with respect to your applications, you have all the necessary expertise to create and implement safeguards that (1) anticipate dangerous consequences of failures, (2) monitor failures and their consequences, and (3) lessen the likelihood of failures that might cause harm and take appropriate actions. You agree that prior to using or distributing any applications that include TI products, you will thoroughly test such applications and the functionality of such TI products as used in such applications. TI has not conducted any testing other than that specifically described in the published documentation for a particular TI Resource.

You are authorized to use, copy and modify any individual TI Resource only in connection with the development of applications that include the TI product(s) identified in such TI Resource. NO OTHER LICENSE, EXPRESS OR IMPLIED, BY ESTOPPEL OR OTHERWISE TO ANY OTHER TI INTELLECTUAL PROPERTY RIGHT, AND NO LICENSE TO ANY TECHNOLOGY OR INTELLECTUAL PROPERTY RIGHT OF TI OR ANY THIRD PARTY IS GRANTED HEREIN, including but not limited to any patent right, copyright, mask work right, or other intellectual property right relating to any combination, machine, or process in which TI products or services are used. Information regarding or referencing third-party products or services does not constitute a license to use such products or services, or a warranty or endorsement thereof. Use of TI Resources may require a license from a third party under the patents or other intellectual property of the third party, or a license from TI under the patents or other intellectual property of TI.

TI RESOURCES ARE PROVIDED "AS IS" AND WITH ALL FAULTS. TI DISCLAIMS ALL OTHER WARRANTIES OR REPRESENTATIONS, EXPRESS OR IMPLIED, REGARDING TI RESOURCES OR USE THEREOF, INCLUDING BUT NOT LIMITED TO ACCURACY OR COMPLETENESS, TITLE, ANY EPIDEMIC FAILURE WARRANTY AND ANY IMPLIED WARRANTIES OF MERCHANTABILITY, FITNESS FOR A PARTICULAR PURPOSE, AND NON-INFRINGEMENT OF ANY THIRD PARTY INTELLECTUAL PROPERTY RIGHTS.

TI SHALL NOT BE LIABLE FOR AND SHALL NOT DEFEND OR INDEMNIFY YOU AGAINST ANY CLAIM, INCLUDING BUT NOT LIMITED TO ANY INFRINGEMENT CLAIM THAT RELATES TO OR IS BASED ON ANY COMBINATION OF PRODUCTS EVEN IF DESCRIBED IN TI RESOURCES OR OTHERWISE. IN NO EVENT SHALL TI BE LIABLE FOR ANY ACTUAL, DIRECT, SPECIAL, COLLATERAL, INDIRECT, PUNITIVE, INCIDENTAL, CONSEQUENTIAL OR EXEMPLARY DAMAGES IN CONNECTION WITH OR ARISING OUT OF TI RESOURCES OR USE THEREOF, AND REGARDLESS OF WHETHER TI HAS BEEN ADVISED OF THE POSSIBILITY OF SUCH DAMAGES.

You agree to fully indemnify TI and its representatives against any damages, costs, losses, and/or liabilities arising out of your non-compliance with the terms and provisions of this Notice.

This Notice applies to TI Resources. Additional terms apply to the use and purchase of certain types of materials, TI products and services. These include; without limitation, TI's standard terms for semiconductor products (<http://www.ti.com/sc/docs/stdterms.htm>), [evaluation modules](#), and [samples](http://www.ti.com/sc/docs/sampterm.htm) (<http://www.ti.com/sc/docs/sampterm.htm>).

Mailing Address: Texas Instruments, Post Office Box 655303, Dallas, Texas 75265
Copyright © 2017, Texas Instruments Incorporated